

### Electrolux Major Appliances

Addington Way  
Luton  
Bedfordshire  
LU4 9QQ

telephone: 0870 5 950 950  
web: [www.electrolux.com](http://www.electrolux.com)

### The Thoughtful Design Innovator.

Do you remember the last time you opened a gift that made you say "Oh! How did you know? That's exactly what I wanted!" That's the kind of feeling that the designers at Electrolux seek to evoke in everyone who chooses or uses one of our products. We devote time, knowledge, and a great deal of thought to anticipating and creating the kind of appliances that our customers really need and want.

This kind of thoughtful care means innovating with insight. Not design for design's sake, but design for the user's sake. For us, thoughtful design means making appliances easier to use and tasks more enjoyable to perform, freeing our customers to experience that ultimate 21st century luxury, ease of mind. Our aim is to make this ease of mind more available to more people in more parts of their everyday lives, all over the world. So when we say we're thinking of you, you know we mean just that.

### Electrolux. Thinking of you.

Share more of our thinking at [www.electrolux.com](http://www.electrolux.com)



*Thinking of you*  



TURBO  
TIMER  
OPERATION  
MANUAL



user manual  
portable air conditioners  
(EXP09CS1WI)

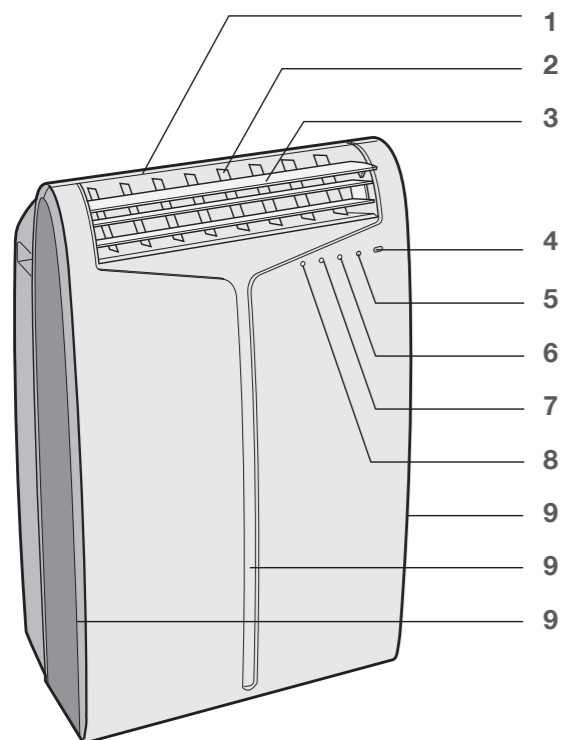

Front view



- 1 Air Outlet
- 2 Vertical louvers
- 3 Horizontal louvers
- 4 Remote control signal receiver window
- 5 MANUAL Button
- 6 OPERATION Lamp (red)
- 7 TIMER Lamp (orange)
- 8 PLASMACLUSTER Lamp (blue)
- 9 Air inlet

Rear view

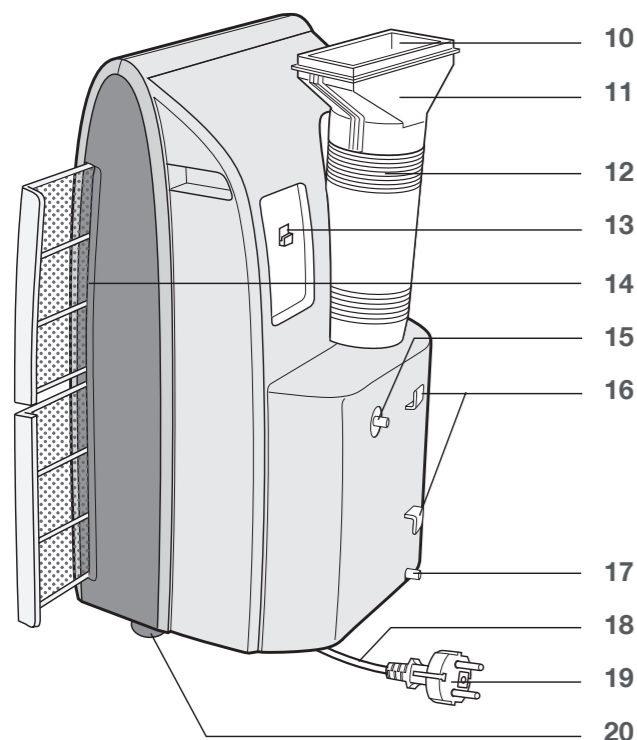

- 10 Exhaust air outlet
- 11 Exhaust adapter
- 12 Exhaust hose
- 13 Remote control hook
- 14 Air filters
- 15 Drainage nozzle and stopcock
- 16 Power supply cord hooks
- 17 Drainpipe nozzle and stopcock
- 18 Power supply cord
- 19 Power plug
- 20 Casters (4)

NOTE: Actual unit may vary slightly from above illustration.

Remote control

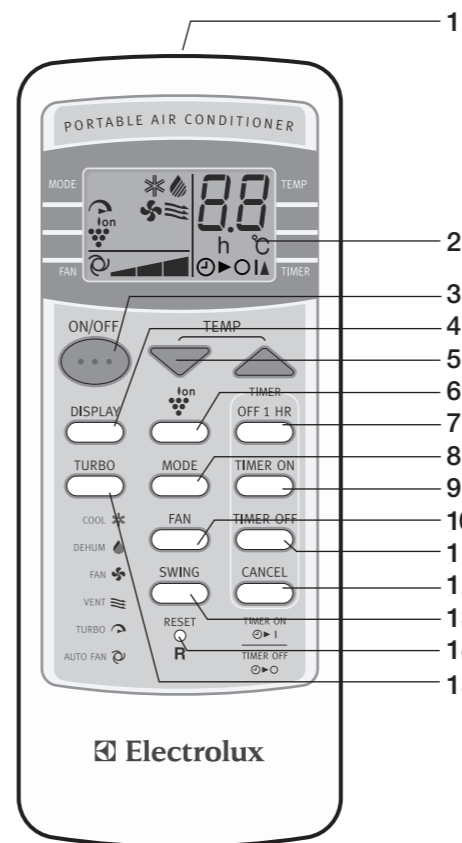

- 1 Transmitter
- 2 Display
- 3 ON/OFF Button
- 4 DISPLAY On/Off Button
- 5 TEMPERATURE Buttons
- 6 PLASMACLUSTER Button
- 7 OFF 1 HR Button
- 8 MODE Button
- 9 TIMER ON Button
- 10 FAN Button
- 11 TIMER OFF Button
- 12 CANCEL Button
- 13 SWING Button
- 14 RESET Button
- 15 TURBO Cool Button

Remote control display

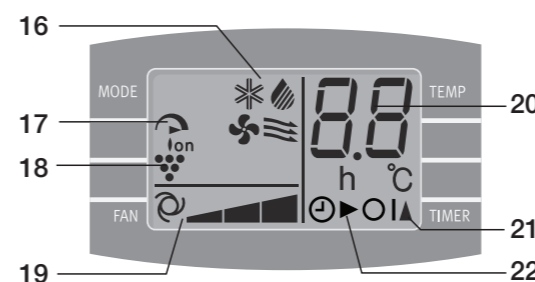

- 16 MODE SYMBOLS
  - \* : COOL    ☁ : DEHUMIDIFICATION
  - ☪ : FAN    ≡ : VENTILATION
- 17 TURBO COOL SYMBOL
- 18 PLASMACLUSTER SYMBOL
- 19 FAN SPEED SYMBOLS
  - ⦿ : AUTO    ▴ : Manual setting
- 20 TEMPERATURE AND TIMER COUNT DOWN INDICATOR
- 21 TRANSMITTING SYMBOL
- 22 TIMER ON/TIMER OFF SYMBOL



## Congratulations

Congratulations and thank you for choosing our portable air conditioner. We are sure you will find your new portable air conditioner a pleasure to use and a great asset to your comfort. Before you use the portable air conditioner, we recommend that you read through the whole user manual, which provides the description of the portable air conditioner and its functions.

To avoid the risks that are always present when you use an electric appliance, it is important that the portable air conditioner is installed correctly and that you read the safety instructions carefully to avoid misuse and hazards. For future reference, please store this manual in a safe place.

## Contents

• <b>Important safety instructions</b>	<b>2</b>
• <b>Operating conditions</b>	<b>5</b>
• <b>Included</b>	<b>5</b>
• <b>Using the remote control</b>	<b>6</b>
• <b>Installation and removal of exhaust hose</b>	<b>7</b>
• <b>Installation of window kit</b>	<b>9</b>
• <b>Cool mode</b>	<b>13</b>
• <b>Dehumidification mode</b>	<b>13</b>
• <b>Fan mode</b>	<b>14</b>
• <b>Ventilation mode</b>	<b>15</b>
• <b>To change air flow direction</b>	<b>15</b>
• <b>Turbo cool operation</b>	<b>16</b>
• <b>Off 1 hr timer</b>	<b>16</b>
• <b>Timer operation</b>	<b>17</b>
• <b>Plasmacluster operation</b>	<b>18</b>
• <b>Manual operation</b>	<b>18</b>
• <b>Drainage</b>	<b>19</b>
• <b>Maintenance</b>	<b>20</b>
• <b>Before calling for service</b>	<b>21</b>
• <b>Warranty</b>	<b>22</b>

## Information on disposal for users

- If you wish to discard this product, please contact your local authorities and ask for the correct method of disposal.
- This air conditioner uses R410A refrigerant.



**Welcome to the world of Electrolux**

Thank you for choosing a first class product from Electrolux, which hopefully will provide you with lots of pleasure in the future. The Electrolux ambition is to offer a wide variety of quality products that make your life more comfortable. You find some examples on the cover in this manual. Please take a few minutes to study this manual so that you can take advantage of the benefits of your new machine. We promise that it will provide a superior User Experience delivering Ease-of-Mind. Good luck!

## Important safety instructions

This manual explains the proper use of your new air conditioner. Please read this manual carefully before using the product. This manual should be kept in a safe place for handy reference.

### **caution**

- Contact authorised service technician for repair or maintenance of this unit.
- Contact the installer for installation of this unit.
- The air conditioner is not intended for use by young children or infirmed persons without supervision.
- Young children should be supervised to ensure that they do not play with the air conditioner.
- There are local council rules regarding maximum allowable noise levels emitted by air conditioners.
- If the power cord is to be replaced, replacement work shall be performed by authorised personnel only.
- Installation work must be performed in accordance with the national wiring standards by authorised personnel only (if applicable). Incorrect connection can cause overheating and fire.
- Take care not to catch fingers on fan when adjusting horizontal louvres.

### Important notes

1. Do not operate unit without the air filter.
2. Do not operate unit near any heat source or open fire.
3. Do not expose the unit to direct sunlight.
4. Always store or move the unit in an upright position.
5. Do not cover the appliance when in operation or immediately after use.
6. Always ensure that when the water pump drain hose is fitted that the hose is run to an effective drain point.
7. Always drain condensate before storing unit.

To prevent injury to the user or other people and property damage, the following instructions must be followed. Incorrect operation due to ignoring instructions may cause harm or damage.

The seriousness is classified by the following indications:

### **warning**

**This symbol indicates the possibility of death or serious injury**

### **caution**

**This symbol indicates the possibility of injury or damage to property**

Meanings of symbols used in this manual are shown below:



















**This symbol indicates never to do this**



**This symbol indicates always do this**

### **warning**

warning	meaning
 <b>Plug in power plug properly</b>	Otherwise, it may cause electric shock or fire due to excess heat generation
 <b>Do not operate or stop the unit by inserting or pulling out the power plug</b>	It may cause electric shock or fire due to heat generation
 <b>Do not damage or use an unspecified power cord</b>	It may cause electric shock or fire If the power cord is damaged, it must be replaced by the manufacturer or an authorised service centre or a similarly qualified person in order to avoid a hazard
 <b>Do not modify power cord length or share the outlet with other appliances</b>	It may cause electric shock or fire due to heat generation
 <b>Do not operate with wet hands or in damp environment</b>	It may cause electric shock
 <b>Do not direct airflow at room occupants</b>	This could harm your health
 <b>Always ensure effective earthing</b>	Incorrect earthing may cause electric shock
 <b>Do not allow water to run into electric parts</b>	It may cause failure of unit or electric shock
 <b>Always install circuit breaker and a dedicated power circuit</b>	Incorrect installation may cause fire and electric shock
 <b>Unplug the unit if strange sounds, smell, or smoke comes from it</b>	It may cause fire and electric shock
 <b>Do not use the socket if it is loose or damaged</b>	It may cause fire and electric shock
 <b>Do not open the unit during operation</b>	It may cause fire and electric shock
 <b>Keep firearms away</b>	It may cause fire
 <b>Do not use the power cord close to heating appliances</b>	It may cause fire and electric shock
 <b>Do not use the power cord near flammable gas or combustibles, such as gasoline, benzene, thinner, etc.</b>	It may cause an explosion or fire
 <b>Ventilate room before operating air conditioner if there is a gas leakage from another appliance</b>	It may cause explosion, fire and burns
 <b>Do not disassemble or modify unit</b>	It may cause failure and electric shock



**caution**

<b>caution</b>	<b>meaning</b>
⊘ <b>When the air filter is to be removed, do not touch the metal parts of the unit</b>	It may cause an injury
⊘ <b>Do not clean the air conditioner with water</b>	Water may enter the unit and degrade the insulation. It may cause an electric shock
Ⓜ <b>Ventilate the room well when used together with a stove, etc.</b>	An oxygen shortage may occur
Ⓜ <b>When the unit is to be cleaned, switch off, and turn off the circuit breaker</b>	Do not clean unit when power is on as it may cause fire and electric shock, it may cause an injury
⊘ <b>Do not place a pet or house plant where it will be exposed to direct air flow</b>	This could injure the pet or plant
⊘ <b>Do not use for special purposes</b>	Do not use this air conditioner to preserve precision devices, food, pets, plants, and art objects. It may cause deterioration of quality, etc.
Ⓜ <b>Stop operation and close the window in storm or cyclone</b>	Operation with windows opened may cause wetting of indoor and soaking of household furniture
Ⓜ <b>Hold the plug by the head of the power plug when taking it out</b>	It may cause electric shock and damage
Ⓜ <b>Turn off the main power switch when not using the unit for a long time</b>	It may cause failure of product or fire

<b>caution</b>	<b>meaning</b>
⊘ <b>Do not place obstacles around air-inlets or inside of air-outlet</b>	It may cause failure of appliance or accident
Ⓜ <b>Always insert the filters securely. Clean filter once every two weeks</b>	Operation without filters may cause failure
⊘ <b>Do not use strong detergent such as wax or thinner – use a soft cloth</b>	Appearance may be deteriorated due to change of product colour or scratching of its surface
⊘ <b>Do not place heavy object on the power cord and ensure that the cord is not compressed</b>	There is danger of fire or electric shock
⊘ <b>Do not drink water drained from air conditioner</b>	It contains contaminants and could make you sick
Ⓜ <b>Use caution when unpacking and installing</b>	Sharp edges could cause injury
Ⓜ <b>If water enters the unit, turn the unit off at the power outlet and switch off the circuit breaker. Isolate supply by taking the power-plug out and contact a qualified service technician</b>	It could cause electric shock and damage

## Points to keep in mind when using your air conditioner



**caution**

### Warnings for use

- Do not modify any part of this product.
- Do not insert anything into any part of the unit.
- Ensure the power supply used has an appropriate voltage rating. Only use a 220V – 240V, 50Hz, 10A mains electricity supply. Use of a power supply with an improper voltage rating can result in damage to the unit and possibly fire.
- Always use a circuit breaker or fuse with the proper amp rating.  
Do not, under any circumstances, use wire, pins or other objects in place of a proper fuse.
- In the event of any abnormality with the air conditioner (eg. a burning smell), turn it off immediately and disconnect the power supply.

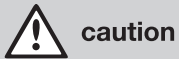

**caution**

### Warning for power supply cord

- This power plug must only be plugged into an appropriate wall socket. Do not use in conjunction with any extension cords.
- Push the power plug securely into the socket and make sure it is not loose.
- Do not pull, deform, or modify the power supply cord, or immerse it in water. Pulling or misuse of the power supply cord can result in damage to the unit and cause electrical shock.
- If the supply cord is damaged, it must be replaced by the manufacturer or its service agent or a similarly qualified person in order to avoid a hazard. Use only the manufacturer specified power cord for replacement.
- This appliance must be earthed. This appliance is equipped with a cord having an earth wire. The plug must be plugged into an outlet that is properly installed and earthed.

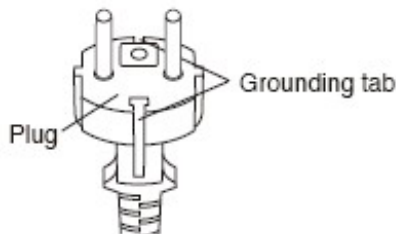

(only for UK)

- This appliance is equipped with a cord that has a earthed wire connected to an earthed pin. The plug must be plugged into a socket that is properly installed and earthed. Do not under any circumstances cut or remove the square earthed pin from this plug.

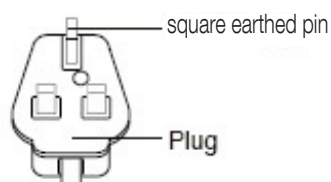

## Usage cautions

- Ventilate the room periodically during use, especially if using gas appliances in conjunction with the air conditioner.
- Be sure to turn the unit off and disconnect the power supply cord before performing any maintenance or cleaning.
- Do not splash or pour water directly onto the unit. Water can cause electrical shock or equipment damage.
- Drainage should be performed whenever moving the air conditioner (see page 19). If any water remains in the tank, it may spill out while being moved.
- To ensure proper drainage, the drainage hose must have no kinks and must not be elevated during dehumidification mode. If not, the drained water may spill out into the room.
- The temperature around the drainage hose must not be below freezing point when used. Drained water may freeze inside the hose, causing water inside the unit to overflow into the room.
- Do not block the exhaust air outlet with obstacles. Cooling performance may be reduced or stop completely.
- Provide a residual current device (RCD) in order to protect against electric shock in accordance with British Standard and Wiring Rules.
- Exposure to direct airflow for an extended period of time could be hazardous to your health. Do not expose occupants, pets, or plants to direct airflow for extended periods of time.
- Do not use this air conditioner for non-specified special purposes (e.g. preserving precision devices, food, pets, plants, and art objects). Usage in such a manner could harm such property.

## Notes on operation

- Allow 3 minutes for the compressor to restart cooling. If you turn the air conditioner off and immediately restart it, allow three minutes for the compressor to restart cooling. There is an electronic device in the unit that keeps the compressor turned off for three minutes for safety.
- In the event of a power failure during use, allow 3 minutes before restarting the unit. After power is reinstated, restart the air conditioner. If the power was off for less than three minutes, be sure to wait at least three minutes before restarting the unit. If you restart the air conditioner within three minutes, a protective device in the unit may cause the compressor to shut off. This protective device will prevent cooling for about 5 minutes. Any previous settings will be cancelled and the unit will return to its initial settings.
- Low temperature operation: Is your unit freezing up? Freezing may occur when the unit is set close to 18°C in low ambient temperature conditions, especially at night. In these conditions, a further temperature drop may cause the unit to freeze. Setting the unit to a higher temperature will prevent it from freezing.
- Dehumidification mode increases room temperature. The unit generates heat during dehumidification mode and the room temperature will rise. Warm air will be blown out from the Exhaust air outlet, but this is normal and does not indicate a problem with the unit.
- This air conditioner blows the warm air generated by the unit outside the room via the exhaust hose while in cool mode. Accordingly, the same amount of air as that blown out will enter the room from outside through any openings into the room.

## Operating conditions

- The air conditioner must be operated within the temperature range indicated in the table below.
- Available for operation at condition of supply voltage 220V to 240V at 50Hz.
- A built-in safety device may cut off operation if the temperature exceeds these limits.
- When cooling operation is performed at high room temperature, the fan may run slightly slower.

Mode	Room temperature	
Cool	upper limit	35°C
	lower limit	18°C
Dehumidification	lower limit	15°C

### Energy efficiency tips

- **Avoid direct sunlight**  
Close blinds, drapes or shades to keep out direct sunlight while in cooling mode.
- **Keep the filter clean**  
Keeping the filter clean greatly aids efficient operation. A dirty filter blocks the flow of air, making your air conditioner work harder and less efficiently. See page 15 on how to clean the filter.
- **Turn off unnecessary lights**  
Your air conditioner must remove the heat produced by your lights or other heat-producing appliances. Turn off any lights or appliances that are not in use.
- **Turn off the air conditioner when no one is home**  
Use only when necessary. The less time the air conditioner is used, the lower the running costs.

### Location

- The air conditioner should be placed on a firm foundation to minimize noise and vibration. For safe and secure positioning, place the unit on a smooth, level floor strong enough to support the unit.
- The unit has casters to aid placement, but it should only be rolled on smooth, flat surfaces. Use caution when rolling on carpet surfaces. Do not attempt to roll the unit over objects.
- The unit must be placed within reach of a properly rated earthed socket.
- Never place any obstacles around the air inlet or outlet of the unit.
- Allow at least 30 cm of space on either side from the wall for efficient air-conditioning.

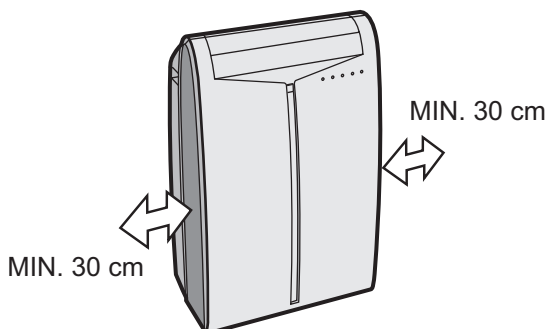

## Included

Exhaust hose (1)

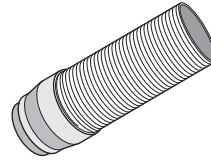

Window exhaust adapter (1)

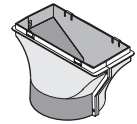

Insect guard net (1)



Remote control (1)

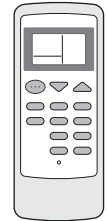

Battery (2)  
(AAA.1.5V)



Hose clamp (1)



Suction disk (1)



Manual (1)



## Included only together with "window kit"

Extension panel (1)

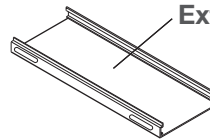

Foam seal (1)

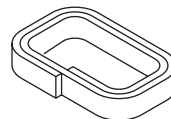

Foam seal (3)  
(adhesive type) A

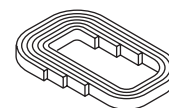

Foam seal (1)  
(adhesive type) B

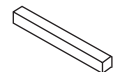

Bracket (1)



Screw (8)



Rain guard (2)



Exhaust cover (1)

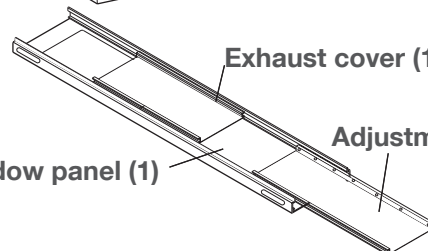

Adjustment panel (1)

Window panel (1)

### Suggested tools for window kit installation

1. Screwdriver (medium size Phillips)
2. Tape measure or ruler
3. Knife or scissors
4. Saw (in the event that the window panel needs to be cut down in size because the window is too narrow for direct installation)



## Using the remote control

### Loading the batteries (use two AAA 1.5V) alkaline batteries

1. Remove the battery cover at the back of the remote control.
2. Insert batteries into the compartment, making sure the ⊕ and ⊖ polarities are correctly aligned, as shown.
  - Lines will appear on the display when batteries are properly installed.
3. Reattach the battery cover.
4. Press the RESET button using a thin pointed implement.

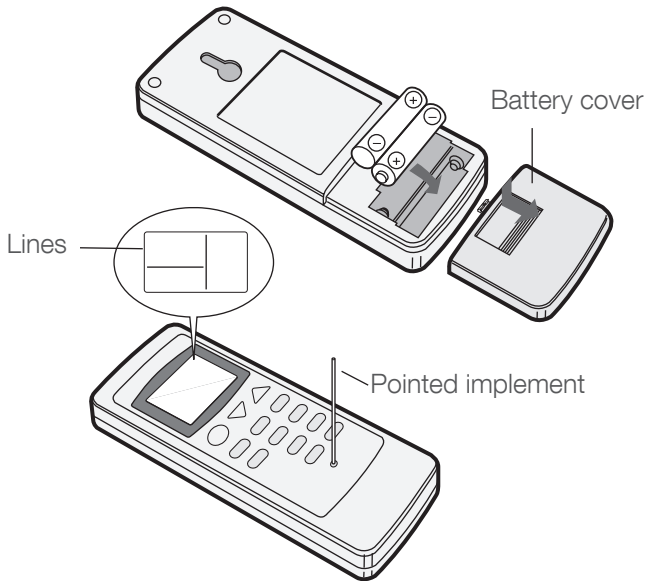

#### NOTES:

- Batteries should last approximately one year under normal use.
- When replacing the batteries, always change both batteries at the same time, and make sure they are the same type.
- If the remote control does not operate normally after replacing the batteries, press the RESET button using a thin pointed implement.
- If you will not be using the unit for a prolonged period, remove the batteries from the remote control.
- Do not use rechargeable batteries.

## How to use the remote control

Point the remote control towards the unit's signal receiver window and press the desired button. A beep will sound when the unit receives the signal.

- Make sure nothing, such as curtains, block the signal receiver window.
- The remote control operates up to 7 meters away.

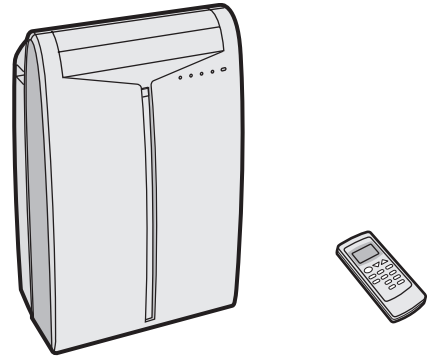

### **caution**

- Do not expose the signal receiver window to direct sunlight. This may adversely affect its operation. If necessary, close curtains to block out the sunlight.
- Use of a fluorescent lamp in the same room may interfere with transmission of the signal.
- The unit may be affected by signals emitted from other remote controllers for televisions, VCRs or other equipment used in the same room.
- Do not leave the remote control exposed to direct sunlight or near a heater. Protect the remote control from moisture and shock which can discolour or damage it.

To prevent the remote control from being misplaced, hook it to the unit when not in use.

When attached, to remove the remote control from the unit, lift the remote control up slightly and pull it out from the remote control hook.

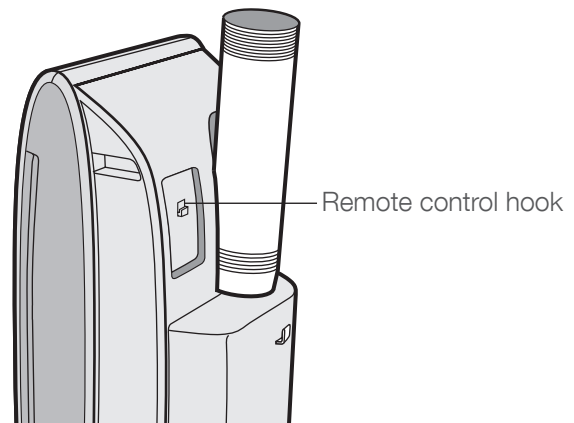

## Installation and removal of exhaust hose

### Installation without "window kit"

The exhaust hose must be installed or removed in accordance with the usage mode.

Mode	Exhaust hose
Cool, fan, ventilation	Install
Dehumidification	Remove

The exhaust hose should be as short as possible for operational efficiency; however, it must not be twisted or bent.

#### Unacceptable

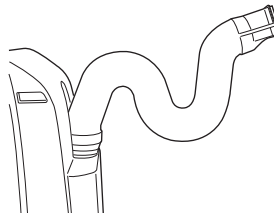

#### Acceptable

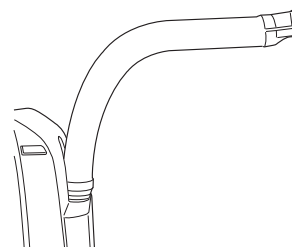

#### Acceptable

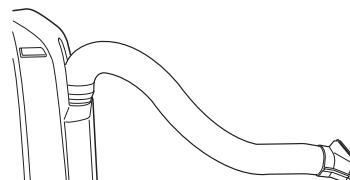

### Installation of the exhaust hose

#### 1. Attach the insect guard net to the exhaust adapter.

Push the insect guard net firmly to ensure that four projections on the exhaust adapter fit into the four holes on it.

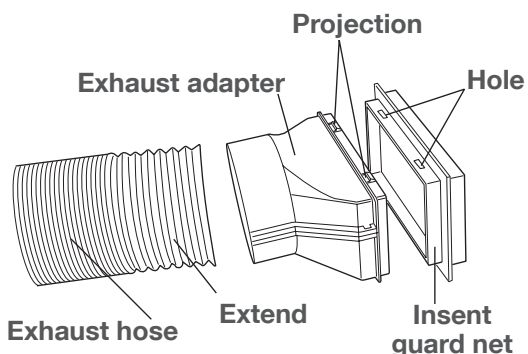

#### 2. Attach the Exhaust adapter to the exhaust hose.

Extend one end of the exhaust hose and insert it into the Exhaust adapter, and turn it (approx. three times) until it stops.

Make sure they are securely attached afterwards.

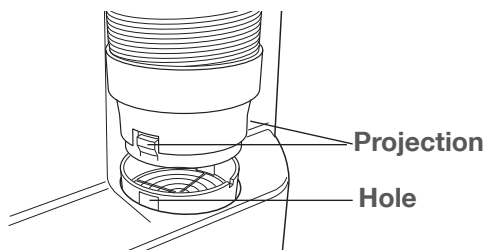

#### 3. Attach the exhaust hose adapter to the unit.

Insert the two projections on the exhaust hose adapter into the two holes on the unit, and firmly attach them to each other.

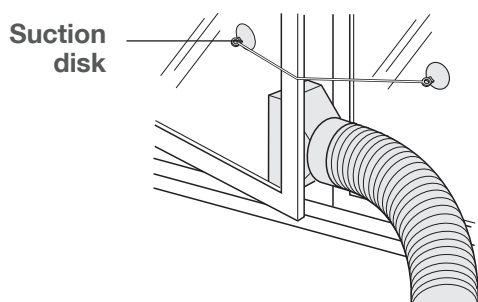

### Removal of the exhaust hose

#### 1. Remove the exhaust hose adapter from the unit.

Lift up and remove the exhaust hose adapter from the unit by pushing down on the two projections.

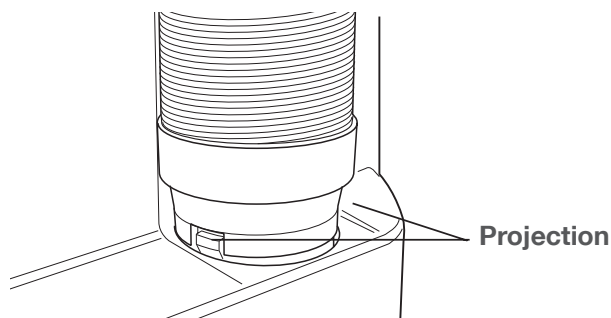

## Installation and removal of exhaust hose

### Installation only together with “window kit”

The exhaust hose must be installed or removed in accordance with the usage mode indicated in the table below

Mode	Exhaust hose
Cool, fan, ventilation	Install
Dehumidification	Remove

### Installation of the exhaust hose

1. Attach the window exhaust adapter to the exhaust hose
  - Extend one end of the exhaust hose and insert it into the window exhaust adapter, and turn it (approx. three times) until it stops.
  - Make sure they are securely attached.

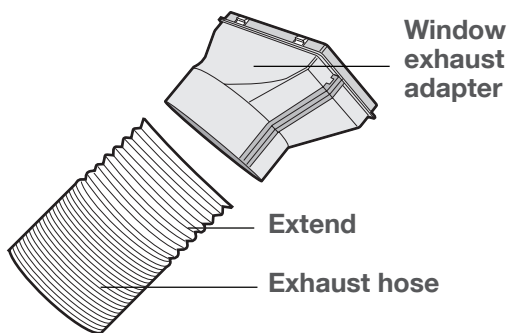

2. Attach the exhaust hose couple to the unit
  - Insert the two projections on the exhaust hose couple into the two holes on the unit, and firmly attach them to each other.

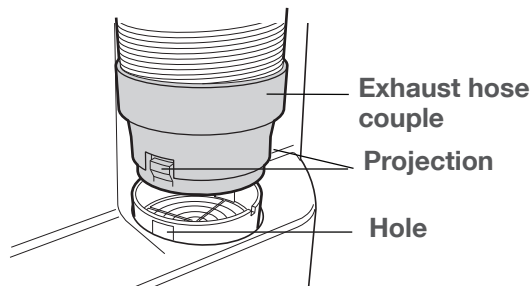

3. Slide and open the exhaust cover on the window panel, and attach the window exhaust adapter
  - Surface of window exhaust adapter marked “TOP” should be at the top when it is installed in a doublehung sash window.
  - Surface of window exhaust adapter marked “TOP” should be on the window frame side when it is installed in a sliding sash window.

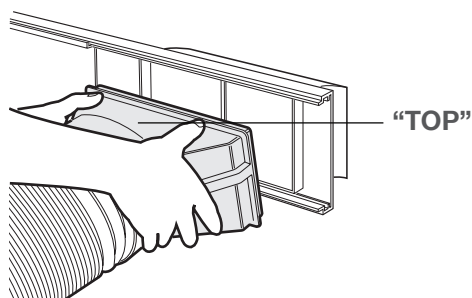

The exhaust hose should be as short as possible for operational efficiency; however, it must not be twisted or bent.

### Unacceptable

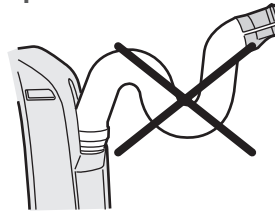

### Acceptable

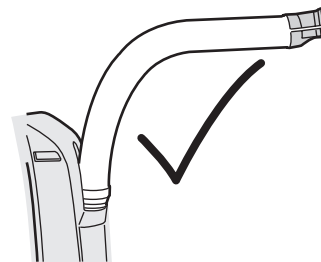

### Acceptable

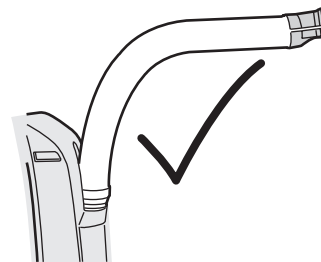

### Removal of the exhaust hose

1. Remove the window exhaust adapter.
  - Pull out and remove the window exhaust adapter by pushing down the two “PUSH” markings, and slide and close the exhaust cover in the window panel.

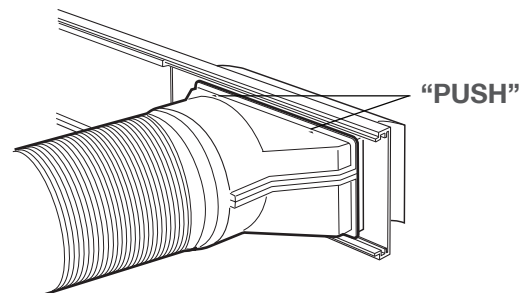

2. Remove the exhaust hose couple from the unit.
  - Lift up and remove the exhaust hose couple from the unit by pushing down on the two projections.

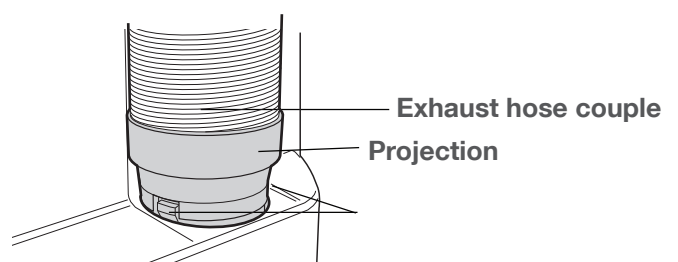

## Installation of window kit

### Window kit is not supplied to all markets

#### Installation in a double-hung sash window

1. Connect the rain guards to the insect guard net.
  - Insert all three projections on each rain guard into the holes in the insect guard net.
  - Side "A" will now be uppermost, as indicated in the diagram.

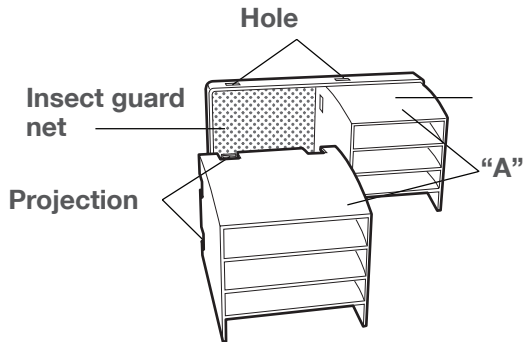

2. Attach the guard combined above to the window panel
  - Push the insect guard net firmly to ensure that its four projections fit into the holes in the window panel.
  - Side "A" will now be at the top, as indicated in the diagram.

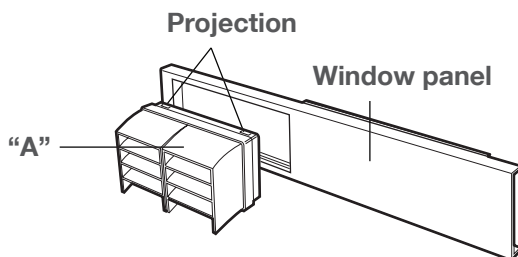

3. Cut the foam seal A (adhesive type) to the proper length and attach it to the window sill

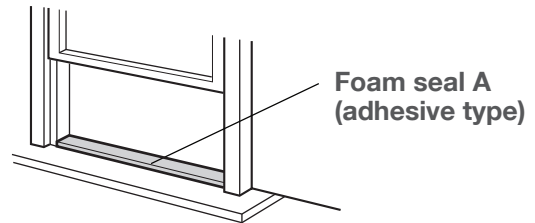

4. Attach the window panel to the window sill

- (A) If the inner width of the window is between 559mm and 609mm inclusive:  
*The window panel cannot be installed in windows less than 559mm wide, as you will be unable to shut the exhaust cover.*  
*In such cases the exhaust cover will have to be removed prior to installing the window panel.*
- Remove the adjustment panel from the window panel, and cut the window panel to the same width as the window
  - Open the window sash and place the window panel on the window sill
  - Secure the window panel to the window stool with 2 screws

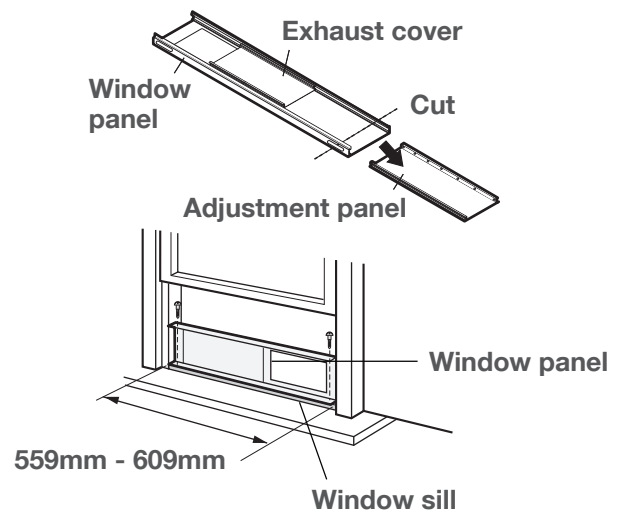

**Installation in a double-hung sash window (cont.)**

(B) If the inner width of the window is between 609mm and 934mm inclusive:

- Open the window sash and place the window panel on the window stool.
- Slide the adjustment panel to fit the window frame width.
- Secure the window panel to the sill with 3 screws.

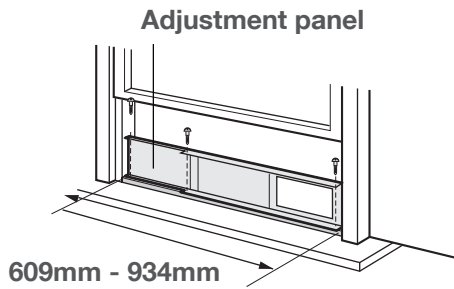

(C) If the inner width of the window is between 934mm and 1219mm inclusive:

- Attach the extension panel to the adjustment panel.
- Open the window sash and place the window panel on the window stool.
- Slide the adjustment and extension panels to fit the window frame width.
- Secure the window panel to the window stool with 4 screws.

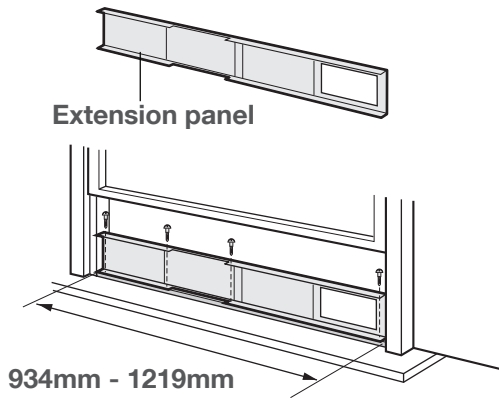

5. Cut the foam seals A and B (adhesive type) to the proper length and attach it to the window panel
- Attach foam seal A to the window panel and extension panel, and attach foam seal B to the adjustment panel.

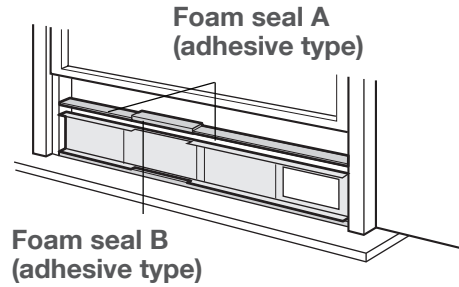

6. Close the window sash securely against the window panel

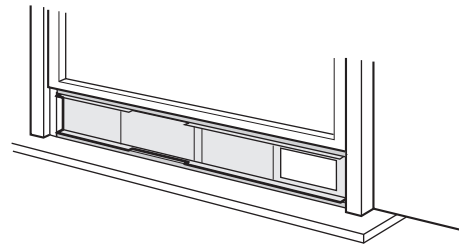

7. Cut the foam seal to an appropriate length and seal the opening between the top of the inner window sash and the outer window sash

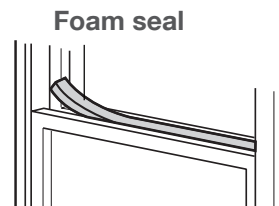

8. Attach a bracket with the screw

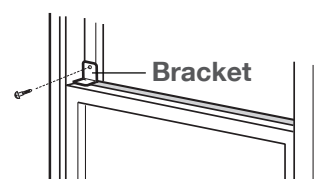

### Installation in a sliding sash window

1. Connect the rain guards to the insect guard net
  - Insert all three projections on each rain guard into the holes in the insect guard net.
  - Side "A" will now be uppermost, as indicated in the diagram.

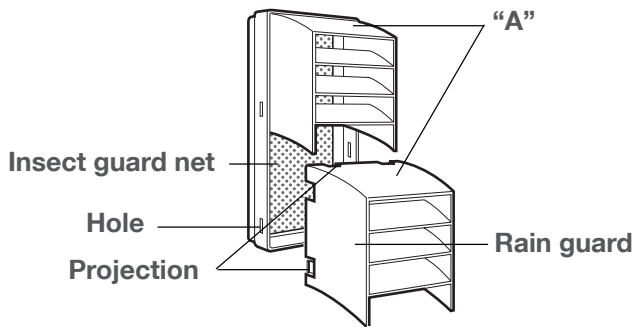

2. Attach the guard combined with insect guard net to the window panel
  - Push the insect guard net firmly to ensure that its four projections fit into the holes in the window panel.
  - Side "A" will now be at the top, as indicated in the diagram, when it is installed in the window.

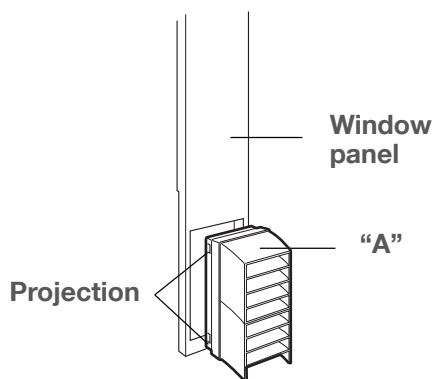

3. Cut the foam seal A (adhesive type) to the proper length and attach it to the window frame

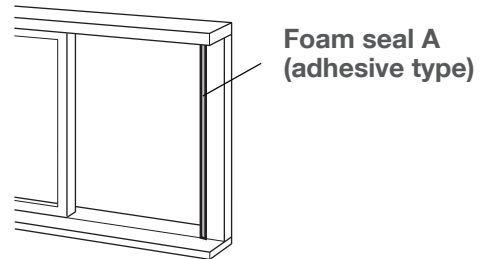

4. Install the window panel into the window frame

- (A) If the inner height of the window is between 559mm and 609mm inclusive:  
*The window panel cannot be installed in windows less than 559mm high, as you will be unable to shut the exhaust cover.*  
*In such cases the exhaust cover will have to be removed prior to installing the window panel.*
- Remove the adjustment panel from the window panel, and cut the window panel to the same height as the window.
  - Open the window sash and place the window panel on the window frame.
  - Secure the window panel to the window frame with 2 screws.

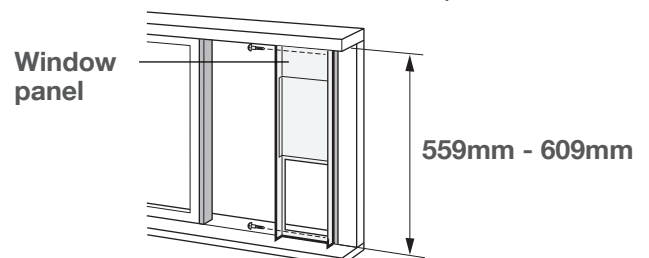
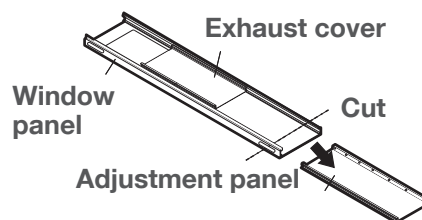

**Installation in a sliding sash window (cont.)**

(B) If the inner width of the window is between 609mm and 934mm inclusive:

- Open the window sash and place the window panel on the window stool.
- Slide the adjustment panel to fit the window frame width.
- Secure the window panel to the sill with 3 screws.

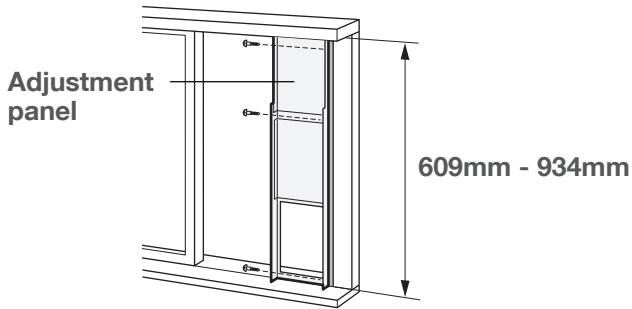

5. Cut the foam seals A and B (adhesive type) to the proper length and attach it to the window panel

- Attach foam seal A to the window panel and extension panel, and attach foam seal B to the adjustment panel.

**Foam seal B (adhesive type)**

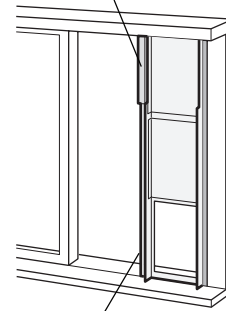

**Foam seal A (adhesive type)**

6. Close the window sash securely against the window panel

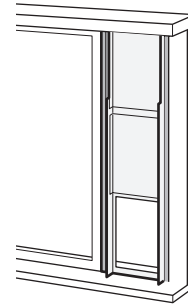

(C) If the inner width of the window is between 609mm and 934mm inclusive:

- Attach the extension panel to the adjustment panel.
- Open the window sash and place the window panel on the window stool.
- Slide the adjustment and extension panels to fit the window frame width.
- Secure the window panel to the window stool with 4 screws.

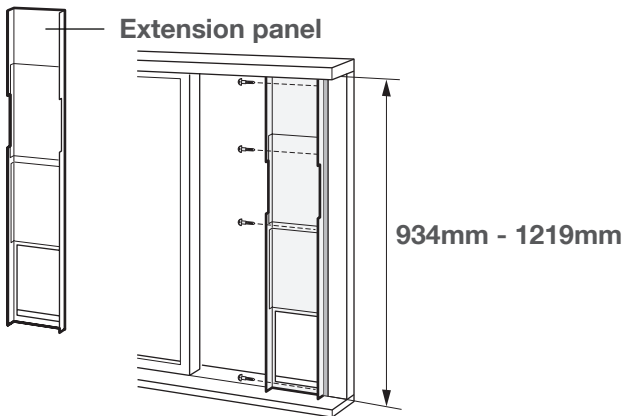

7. Cut the foam seal to an appropriate length and seal the opening between the top of the inner window sash and the outer window sash

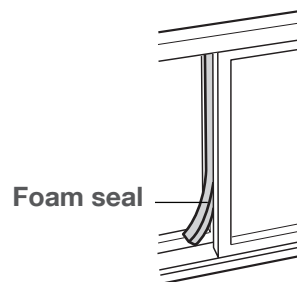

8. Attach a bracket with the screw

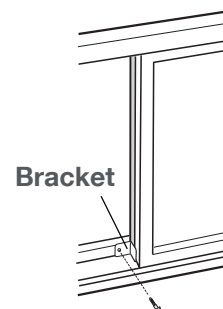

## Cool mode

Install the exhaust hose (see page 7-8, turn the drainage nozzle to the CLOSE position, and check the drainage nozzle is covered with the stopcock.

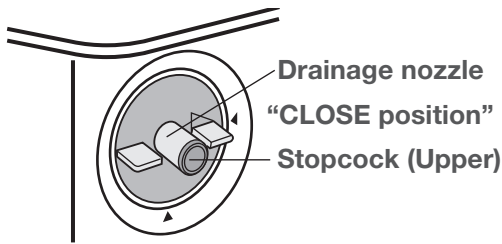

1. Press the MODE button to select COOL mode.



2. Press the ON/OFF button to start operation.
  - The red OPERATION lamp on the unit will illuminate. Make sure they are securely attached.
3. Press the TEMPERATURE button to set the desired temperature.
  - The temperature can be set within the range of 18°C to 32°C.

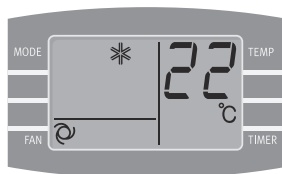

4. Press the FAN button to set the desired fan speed.



### To turn off

Press the ON/OFF button again.

- The red OPERATION lamp on the unit will turn off.

### NOTES:

- To minimise noise it is recommended that during cooling mode the drainage nozzle should remain in the CLOSE position.
- To prevent water saturation ensure that stopcocks are always fitted when not using separate drainage.

## Dehumidification mode

**In this mode, the air conditioner dehumidifies the room**

1. Remove the exhaust hose (see page 7-8).
2. Turn the drainage nozzle to the OPEN position.

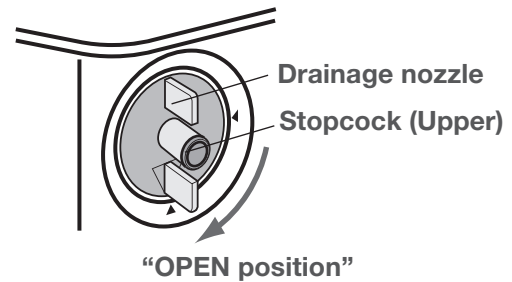

3. Pull the stopcock (upper) out from the drainage nozzle.
  - When the stopcock (upper) is removed, a small amount of water may be discharged from the drainage nozzle.
  - Always perform this procedure with the unit turned off. Drain water will squirt out if attempted during operation.
4. Insert the hose clamp into a standard commercially-available hose (12.7mm inner diameter, 16.7mm outer diameter).

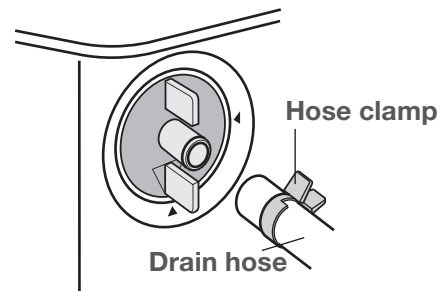

5. Attach the hose to the drainage nozzle, and secure it with the hose clamp.
  - Depending on room condition, approximately 28 litres of water per day (24 hours) will be dehumidified. Prepare some kind of bucket of appropriate size to collect drain water, or take some appropriate measure to drain the water outside of the room, so that drain water will not overflow or soak your room.
  - Set the hose sloping downwards for easier drainage. Moreover, do not bend the hose at any point, nor allow the end to be submerged in water.

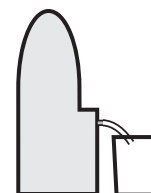



## Dehumidification mode (cont.)

6. Press the MODE button to select DEHUMIDIFICATION mode.



7. Press the ON/OFF button to start operation.
- The red OPERATION lamp on the unit will illuminate.
  - The temperature cannot be set.
  - The fan speed is preset to AUTO and cannot be changed.

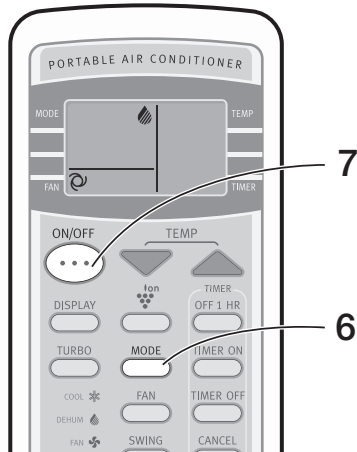

### To turn off

Press the ON/OFF button again.

- The red OPERATION lamp on the unit will turn off.



*The unit generates heat during dehumidification mode and the room temperature will rise. Install the exhaust hose if you do not want the room temperature to rise. This will help to slightly drop the room temperature, but dehumidification performance will become less effective than when operating without the exhaust hose.*

## Fan mode

**In this mode, the air conditioner simply circulates the air without cooling it**

Turn the drainage nozzle to the CLOSE position, and check the drainage nozzle is covered with the stopcock.

1. Press the MODE button to select FAN mode.



2. Press the ON/OFF button to start operation.
- The red OPERATION lamp on the unit will illuminate.
  - The temperature cannot be set.
3. Press the FAN button to set the desired fan speed.

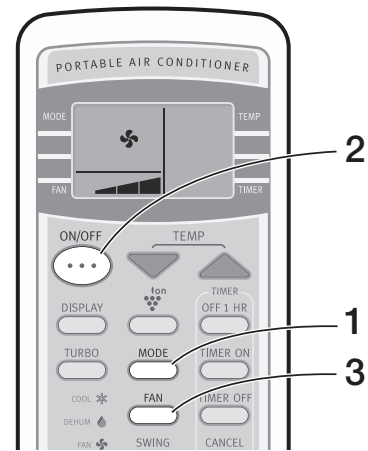

### To turn off

Press the ON/OFF button again.

- The red OPERATION lamp on the unit will turn off.

## Ventilation mode

In this mode, the air conditioner ventilates the air to outdoors

Install the exhaust hose (See Page 7-8), turn the drainage nozzle to the CLOSE position, and check the drainage nozzle is covered with the stopcock (upper).

1. Press the MODE button to select VENT mode.



2. Press the ON/OFF button to start operation.
  - The red OPERATION lamp on the unit will illuminate.
  - The temperature cannot be set.
3. Press the FAN button to set the desired fan speed.
  - Although the louvres are closed and no air blows out into the room, the external ventilation fan speed changes.

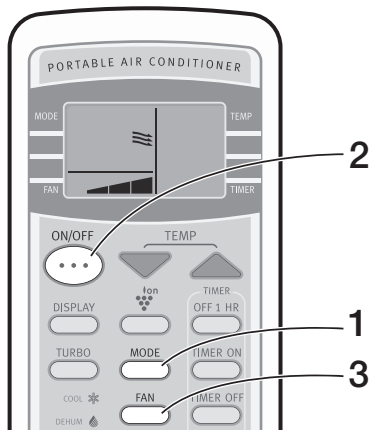

### To turn off

Press the ON/OFF button again.

- The red OPERATION lamp on the unit will turn off.

## To change air flow direction

### Up/down air flow direction

1. Press the ON/OFF button to start operation.
  - The red OPERATION lamp on the unit will illuminate.
2. Press the SWING button on the remote control.
  - The horizontal louvres will swing continuously.
3. Press the SWING button again when the horizontal louvres are at the desired position.
  - The horizontal louvres will stop moving.
  - The adjusted position will be memorized and the same position will be set automatically when operated the next time.

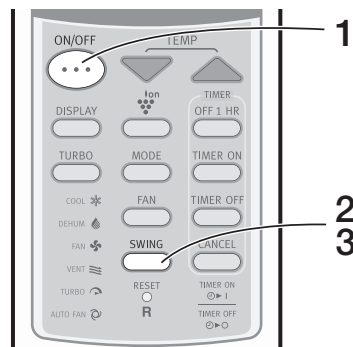

### NOTE

- During VENTILATION mode, UP/DOWN air flow direction cannot be changed.

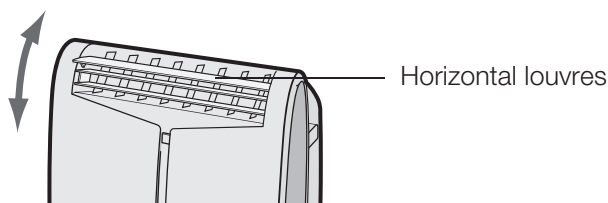

### Left/right air flow direction

Hold the vertical louvre as shown in the diagram below and adjust the air flow direction.

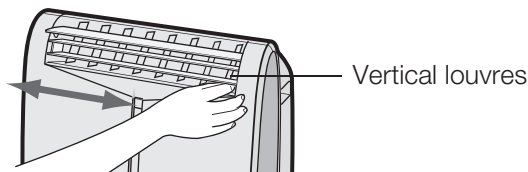

**caution**

Never attempt to adjust the horizontal louvres manually.

- Manual adjustment of the horizontal louvres can cause the unit to malfunction when the remote control is used for adjustment.
- When the horizontal louvres are positioned at the lowest position in the COOL or DEHUMIDIFICATION mode for an extended period of time, condensation may result.

Do not adjust the vertical louvres to the extreme left or right in the COOL mode with the fan speed set to "QUIET (■)" for an extended period of time.

Condensation may form on the louvres.

## Turbo cool operation

**In this operation, the air conditioner fan works at extra high speed with a setting temperature of 15°C**

1. Press the TURBO cool button during cooling mode.
  - The remote control will display “”.
  - The temperature display will go off.

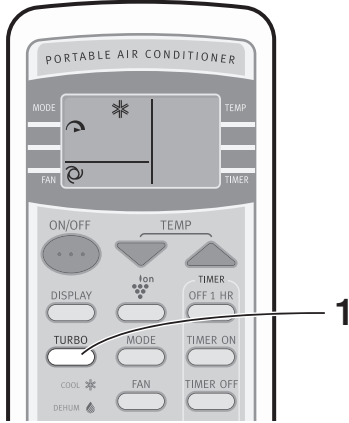

### To cancel

Press the TURBO cool button again.

- TURBO cool operation is also cancelled when the mode is changed, or when the unit is turned off.

### NOTES:

- You cannot set the temperature or fan speed during TURBO cool operation.
- The fan returns to the HIGH speed setting after the unit has run for 30 minutes in TURBO cool mode.
- The extra high fan speed may automatically slow down to protect the unit.

## Off 1 hr timer

**When the OFF 1 HR TIMER is set, the unit will automatically turn off after one hour**

1. Press the OFF 1HR button.
  - The remote control displays “”.
  - The orange TIMER lamp on the unit will illuminate.
  - The unit will stop operating after one hour.

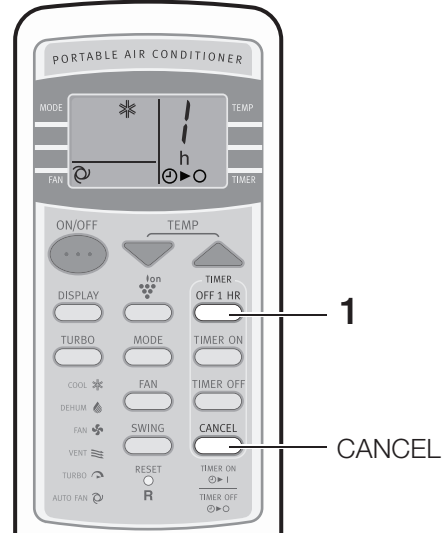

### To cancel

Press the CANCEL button.

- The orange TIMER lamp on the unit will turn off. Alternatively, turn the unit off by pressing the ON/ OFF button.
- The red OPERATION lamp and the orange TIMER lamp on the unit will turn off.

### NOTES:

- The OFF 1 HR TIMER operation has priority over TIMER ON and TIMER OFF operations.
- If the OFF 1 HR TIMER is set while the unit is not operating, the unit will operate for an hour at the formerly set condition before turning off.
- If you wish to operate the unit for another hour before the OFF 1 HR TIMER is activated, press the OFF 1 HR TIMER button again during operation.

## Timer operation

### Timer off

The unit will turn off automatically according to your setting. Timer duration can be set from a minimum of half an hour (30 minutes) to a maximum of 12 hours. Up to 10 hours, you can set in half-hour (30-minute) increments and from 10 to 12 hours, you can set in 1-hour increments.

Point the remote control at the signal receiver window on the unit.

1. Press the TIMER OFF (🕒▶️⏻) button and set the time as desired.

- The time setting will change as you press the button as follows.



Hold the button down to speed through the settings.

- The orange TIMER lamp on the unit will illuminate.
- The unit will emit a beep when it receives the signal.
- Once set, the time setting will countdown and show the remaining time.

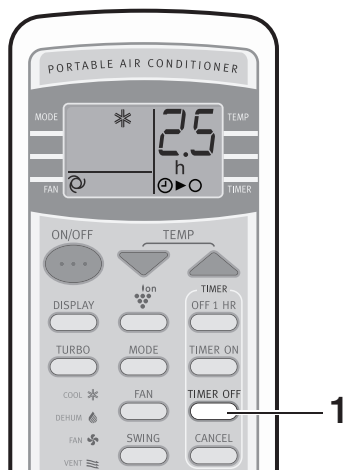

Display shows the unit set to turn off in 2.5 hours.

### To cancel

Press the CANCEL button.

- The orange TIMER lamp on the unit will turn off.

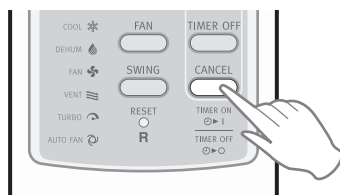

### NOTES ON TIMER SETTING AND OPERATION

- The last time setting will be memorized and will appear on the remote control display the next time you set the TIMER OFF or TIMER ON.
- The TIMER OFF and TIMER ON can not be set simultaneously. Only the most recent TIMER setting will be valid.
- When the OFF 1 HR TIMER is set, the TIMER OFF and TIMER ON settings are unavailable.
- If the OFF 1 HR TIMER is set while the TIMER OFF or TIMER ON is activated, the TIMER ON or TIMER OFF setting will be cancelled.
- If a power failure occurs while the TIMER OFF or TIMER ON is set, the TIMER setting will be cancelled and will not be retrieved even after the power is restored.

### Timer on

The unit will turn on automatically according to your setting. Timer duration can be set from a minimum of half an hour (30 minutes) to a maximum of 12 hours. Up to 10 hours, you can set in half-hour (30-minute) increments and from 10 to 12 hours, you can set in 1-hour increments.

Point the remote control at the signal receiver window on the unit.

1. Press the TIMER ON (🕒▶️⏻) button and set the time as desired.

- The time setting will change as you press the button as follows.

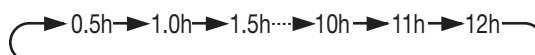

Hold the button down to speed through the settings.

- The orange TIMER lamp on the unit will illuminate.
- The unit will emit a beep when it receives the signal.
- Once set the time setting will countdown and show the remaining time.

Select the mode, temperature, fan speed setting and PLASMACLUSTER operation as desired.

- When the temperature is set with the TIMER ON, the temperature will show in the display for 5 seconds and then return to the countdown display.
- If you do not change the setting, the unit will operate using the most recent setting.

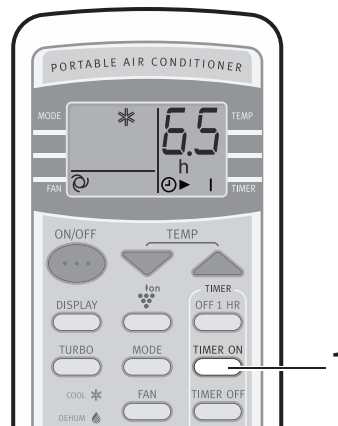

Display shows the unit set to turn on in 6.5 hours.

### To cancel

Press the CANCEL button.

- The orange TIMER lamp on the unit will turn off.

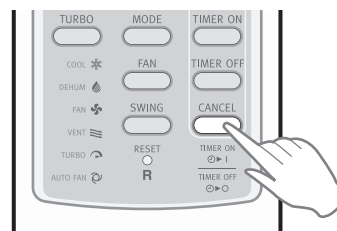

## Plasmacluster operation

The Plasmacluster ion generator inside the air conditioner will release positive and negative Plasmacluster ions into the room. Approximately the same numbers of positive and negative ions released into the air will reduce some airborne mould, allergens and viruses.

1. Press the PLASMACLUSTER button during operation.
  - The remote control will display “ion”.
  - The blue PLASMACLUSTER lamp on the unit will illuminate.

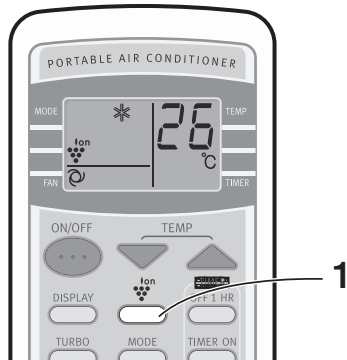

### To cancel

Press the PLASMACLUSTER button again.

- The PLASMACLUSTER lamp on the unit will turn off.

### NOTES:

- Use of the PLASMACLUSTER function will be memorised and it will be activated the next time you turn on the air conditioner.
- To turn off the PLASMACLUSTER lamp, press the DISPLAY button.
- PLASMACLUSTER operation cannot be set during VENTILATION mode.

## Manual operation

Use this mode when the remote control is not available

1. Press the MANUAL button on the unit.
  - The red OPERATION lamp on the unit will illuminate.
  - If the unit has not been unplugged since its last operation it will resume operation at its last settings.
  - If the unit has been unplugged since its last operation, it resumes operation in the cooling mode, set at 20°C with the fan speed set to AUTO.

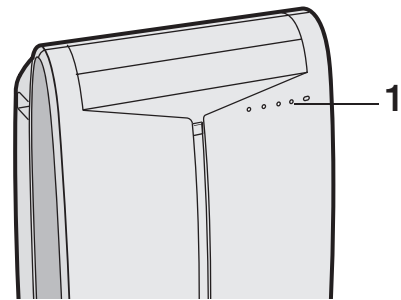

### To turn off

Press the MANUAL button again.

- The red OPERATION lamp on the unit will turn off.

### NOTES:

- If the MANUAL button is pressed during normal operation, the unit will turn off.
- Upon starting MANUAL operation, the drainage pump inside the unit runs for about a minute, which may produce an audible gurgling sound.

## Drainage

Prepare for drainage and drain out water within the unit in the following cases

If the unit stops operating and the TIMER and OPERATION lamps are blinking, this indicates that the water tank inside the unit is full.

1. Make sure to turn the unit off.
2. Turn the drainage nozzle to the OPEN position.

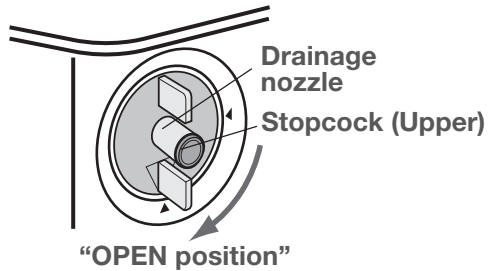

3. Pull the stopcock (upper) out from the drainage nozzle.
  - When the stopcock (upper) is removed, a small amount of water may be discharged from the drainage nozzle.
4. Insert the hose clamp onto the drain hose.
5. Attach the drain hose to the drainage nozzle, and secure it with the hose clamp.
  - Prepare for draining, as drain water will come out through the drain hose during operation.

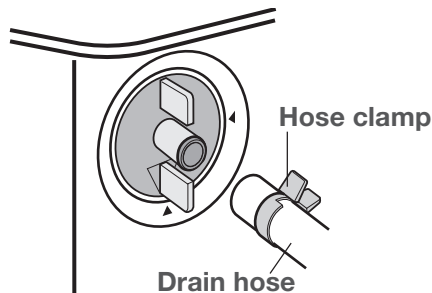

6. Press the MANUAL button on the unit twice.
  - The water will drain out through the drain hose. Maximum amount of water that may be drained out is approximately 2 litres.
  - The OPERATION and TIMER cool lamps will be blinking.
7. When drainage water stops running out from the drain hose, turn the unit off by pressing MANUAL button.
  - This should take about one minute to complete.
8. Remove the drain hose from the drainage nozzle, and replace the stopcock (upper).
  - Keep the hose clamp for future use.
9. Turn the drainage nozzle to the CLOSE position.

**Whenever the unit is moved (to prevent water within the unit from spilling).**

**When the unit is not going to be used for a long time**

1. Carry out the previous procedures from 1 to 5.
2. Press the MANUAL button on the unit.
  - The water will drain out through the drain hose. Maximum amount of water that may be drained out is approximately 2 litres.
  - The OPERATION lamps will illuminate.
3. When drainage water stops running out from the drain hose, turn the unit off by pressing the MANUAL button.
  - This should take about one minute to complete.
4. Remove the drain hose from the drainage nozzle, and replace the stopcock (upper).
  - Keep the hose clamp for future use.
5. Turn the drainage nozzle to the CLOSE position.
6. Remove the stopcock (lower) from the drainpipe nozzle, and completely drain any water within the unit.
  - Always prepare a receptacle to collect the water before draining. Maximum amount of water that may be drained out is approximately 0.2 litres.
7. Replace the stopcock (lower) to the drainpipe nozzle.

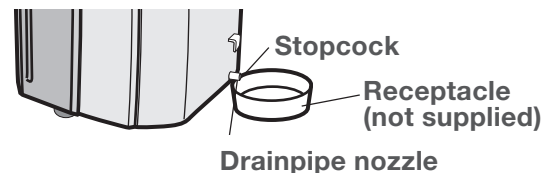

## Maintenance

Be sure to switch off and disconnect the power from the wall socket before performing any maintenance.

### *Cleaning the filters*

If the filter is clogged with dust, the airflow will be reduced, resulting in poor cooling performance.

The filter should be cleaned every two weeks.

1. Remove the filters
  - Gently pull the filter handle to the right and slide the filter out of the unit.
2. Clean the filters
  - Use a vacuum cleaner to remove any dust. If the filters are very dirty, wash them with detergent and rinse carefully with clean luke warm water. Dry the filters in the shade before reinstalling them.
3. Reinstall the filters
  - Hold the filter handle and gently push the filter back into place. Never operate the unit without the filter. Doing so may result in serious damage to the unit.

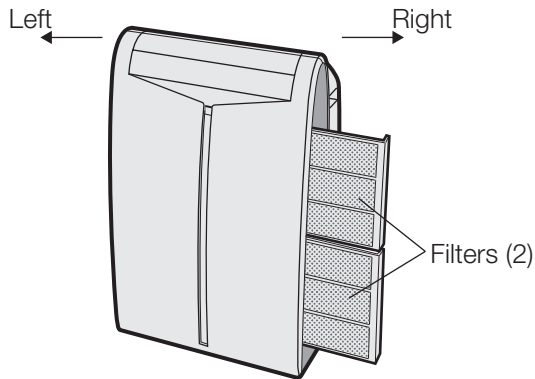

### *Cleaning the unit and the remote control*

Wipe with a soft, dry cloth or with a cloth moistened with a mild soap. Carefully remove any residue by wiping with a damp cloth and dry completely. Avoid splashing water onto the unit. Water can dangerously damage the electrical insulation. Never use harsh chemicals or abrasive cleaners on any part of the unit. To avoid damaging the unit, do not use hot water (not greater than 50°C) when cleaning.

### *Cleaning the insect guard net*

The cooling performance may be reduced or stop completely if the insect guard net becomes clogged with dust.

Clean the insect guard net with a vacuum cleaner or suchlike.

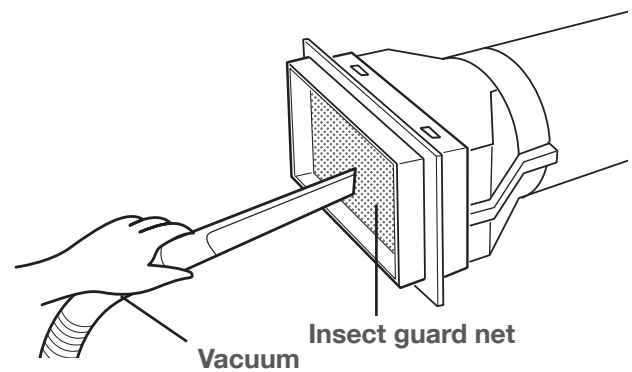

### *Maintenance after air conditioner season*

1. Perform drainage to drain out water within the unit. (See page 19 "When the unit is not used for a long time").
2. Operate the unit in FAN or VENTILATION mode for about half a day to thoroughly dry inside the unit.
3. Clean the filters, then reinstall them.



**caution**

- Ensure that the unit is switched off and power supply is disconnected to the unit prior to cleaning.

## Before calling for service

If the unit appears to be malfunctioning, check the following points before calling for service.

### *Air conditioner does not operate at all*

- Is the unit plugged in or is the plug loose?
- Has the fuse blown or has the circuit breaker tripped?
- Did you restart the unit within 3 minutes of a power failure? If the power was off for less than 3 minutes when you restarted the air conditioner, a protective device may cause the compressor to shut off, preventing cooling for about 5 minutes.
- Are the OPERATION and TIMER lamps on the unit blinking?  
If so, the water tank inside the unit is full. It must be drained. (See page 19)

### **Air conditioner does not cool properly**

- Is the unit set to FAN, DEHUMIDIFICATION or VENTILATION mode? Cooling does not take place in these modes. Change the MODE setting.
- Are the filters clogged with dust?  
Clean and refit the filters.
- Is the cooling coil frozen?  
No air will blow out if the cooling coil is frozen. Run the air conditioner in FAN mode with the fan speed set to "HIGH" until all ice dissipates.
- Is the temperature set properly?
- Is the room exposed to direct sunlight?  
Close the curtains or blinds to minimize solar energy heating the room.
- Is the exhaust hose too long?  
For efficient operation, make the hose as short as possible. The exhaust hose must not be twisted.

### *Sounds*

- The unit may seem rather loud for the first 2 to 3 minutes when turned on. This is the sound of the compressor starting-up and is perfectly normal.
- A soft, swishing noise can be heard immediately after the unit is turned on or off, and also during operation. This is the sound of the refrigerant flowing inside the unit.
- A low buzzing noise is emitted when the unit is generating Plasmacluster ions.
- This air conditioner evaporates water condensed during cooling operation within the unit through the exhaust air outlet. Although a water flowing sound may be heard, this is normal.
- An audible gurgling sound may be heard for about a minute upon starting MANUAL mode. This is the sound of the drainage pump operating inside the unit.
- An audible gurgling sound may be heard when the unit is operated on a gently sloping floor.  
Place the unit on a level floor.

### **Timer does not work properly**

- If a power failure occurs while the TIMER is set, the TIMER setting will be cancelled and will not be retrieved even after the power is restored. This is normal for this unit.

### **The unit fails to react to the remote control signal**

- Check the batteries in the remote control.  
Replace if necessary.
- Try to send the signal again with the remote control pointed directly at the unit's signal receiver window.
- Check whether the remote control batteries are installed with the polarities properly orientated.

### **The discharged air has an odour**

- This is the smell of ozone generated from the Plasmacluster Ion generator. The ozone concentration is very small, posing no adverse effect to your health. The ozone discharged into the air rapidly decomposes, and its density in the room will not increase beyond acceptable levels .



## **Electrolux** Guarantee/ Customer Service

### Standard guarantee conditions

We, Electrolux, undertake that if within 12 months of the date of the purchase this Electrolux appliance or any part thereof is proved to be defective by reason only of faulty workmanship or materials, we will, at our option repair or replace the same FREE OF CHARGE for labour, materials or carriage on condition that:

- The appliance has been correctly installed and used only on the electricity supply stated on the rating plate.
- The appliance has been used for normal domestic purposes only, and in accordance with the manufacturer's instructions.
- The appliance has not been serviced, maintained, repaired, taken apart or tampered with by any person not authorised by us.
- Electrolux Service Force Centre must undertake all service work under this guarantee
- Any appliance or defective part replaced shall become the Company's property.
- This guarantee is in addition to your statutory and other legal rights.

### Exclusions

- Damage or calls resulting from transportation, improper use or neglect, the replacement of any light bulbs or removable parts of glass or plastic.
- Costs incurred for calls to put right an appliance which is improperly installed or calls to appliances outside the United Kingdom.
- Appliances found to be in use within a commercial environment, plus those which are subject to rental agreements.
- Products of Electrolux manufacturer that are not marketed by Electrolux

### Service and Spare Parts

In the event of your appliance requiring service, or if you wish to purchase spare parts, please contact your local Service Force Centre by telephoning

**0870 5 929 929**

Your telephone call will be automatically routed to the Service Force Centre covering your postcode area.

For the address of your local Service Force Centre and further information about Service Force, please visit the website at

**[www.serviceforce.co.uk](http://www.serviceforce.co.uk)**

Before calling out an engineer, please ensure you have read the details under the heading "Something not working" When you contact the Service Force Centre you will need to give the following details:

1. Your name, address and postcode.
2. Your telephone number.
3. Clear concise details of the fault.
4. The model and Serial number of the appliance (found on the rating plate).
5. The purchase date.

Please note a valid purchase receipt or guarantee documentation is required for in guarantee service calls.

### Customer Care

For general enquiries concerning your Electrolux appliance, or for further information on Electrolux products please contact our Customer Care Department by letter or telephone at the address below or visit our website at [www.electrolux.co.uk](http://www.electrolux.co.uk)

Customer Care Department  
Electrolux Major Appliances  
Addington Way  
Luton  
Bedfordshire, LU4 9QQ  
Tel: 08705 950 950 (\*)  
(\*) Calls may be recorded for training purposes

### European Guarantee

This appliance is guaranteed by Electrolux in each of the countries listed at the back of this user manual, for the period specified in the appliance guarantee or otherwise by law. If you move from one of these countries to another of the countries listed below the appliance guarantee will move with

- The appliance guarantee starts from the date you first purchased the appliance which will be evidenced by production of a valid purchase document issued by the seller of the appliance.
- The appliance guarantee is for the same period and to the same extent for labour and parts as exists in your new country of residence for this particular model or range of appliances.
- The appliance guarantee is personal to the original purchaser of the appliance and cannot be transferred to another user.
- The appliance is installed and used in accordance with instructions issued by Electrolux and is only used within the home, i.e. is not used for commercial purposes.
- The appliance is installed in accordance with all relevant regulations in force

The provisions of this European Guarantee do not affect any of the rights granted to you by law.



Albania	+35 5 4 261 450	Rr. Pjeter Bogdani Nr. 7 Tirane
Belgique/België/Belgien	+32 2 363 04 44	Bergensesteenweg 719, 1502 Lembeek
Česká republika	+420 2 61 12 61 12	Budějovická 3, Praha 4, 140 21
Danmark	+45 70 11 74 00	Sjællandsgade 2, 7000 Fredericia
Deutschland	+49 180 32 26 622	Muggenhofer Str. 135, 90429 Nürnberg
Eesti	+37 2 66 50 030	Mustamäe tee 24, 10621 Tallinn
España	+34 902 11 63 88	Carretera M-300, Km. 29,900 Alcalá de Henares Madrid
France	www.electrolux.fr	
Great Britain	+44 8705 929 929	Addington Way, Luton, Bedfordshire LU4 9QQ
Hellas	+30 23 10 56 19 70	4, Limnou Str., 54627 Thessaloniki
Hrvatska	+385 1 63 23 338	Slavonska avenija 3, 10000 Zagreb
Ireland	+353 1 40 90 753	Long Mile Road Dublin 12
Italia	+39 (0) 434 558500	C.so Lino Zanussi, 26 - 33080 Porcia (PN)
Latvija	+37 17 84 59 34	Kr. Barona iela 130/2, LV-1012, Riga
Lituania	+370 5 27 80 609	Verkių 29, 09108 Vilnius, Lithuania
Luxembourg	+35 2 42 43 13 01	Rue de Bitbourg, 7, L-1273 Hamm
Magyarország	+36 1 252 1773	H-1142 Budapest XIV, Erzsébet királyné útja 87
Nederland	+31 17 24 68 300	Vennootsweg 1, 2404 CG - Alphen aan den Rijn
Norge	+47 81 5 30 222	Risløkkvn. 2 , 0508 Oslo
Österreich	+43 18 66 400	Herziggasse 9, 1230 Wien
Polska	+48 22 43 47 300	ul. Kolejowa 5/7, Warsaw
Portugal	+35 12 14 40 39 39	Quinta da Fonte - Edifício Gonçalves Zarco - Q 35 -2774-518 Paço de Arcos
Romania	+40 21 451 20 30	B-dul Timisoara 90, S6, Bucharest
Schweiz - Suisse - Svizzera	+41 62 88 99 111	Industriestrasse 10, CH-5506 Mägenwil
Slovenija	+38 61 24 25 731	Tržaška 132, 1000 Ljubljana
Slovensko	+421 2 43 33 43 22	Electrolux Slovakia s.r.o., Electrolux Domáce spotrebiče SK, Seberíniho 1, 821 03 Bratislava
Suomi	+35 8 26 22 33 00	Konepajanranta 4, 28100 Pori
Sverige	+46 (0)771 76 76 76	Electrolux Service, S:t Göransgatan 143, S-105 45 Stockholm
Türkiye	+90 21 22 93 10 25	Tarlabası caddesi no : 35 Taksim İstanbul
Россия	+7 095 937 7837	129090 Москва, Олимпийский проспект, 16, БЦ "Олимпик"

